

Schnitt A-A

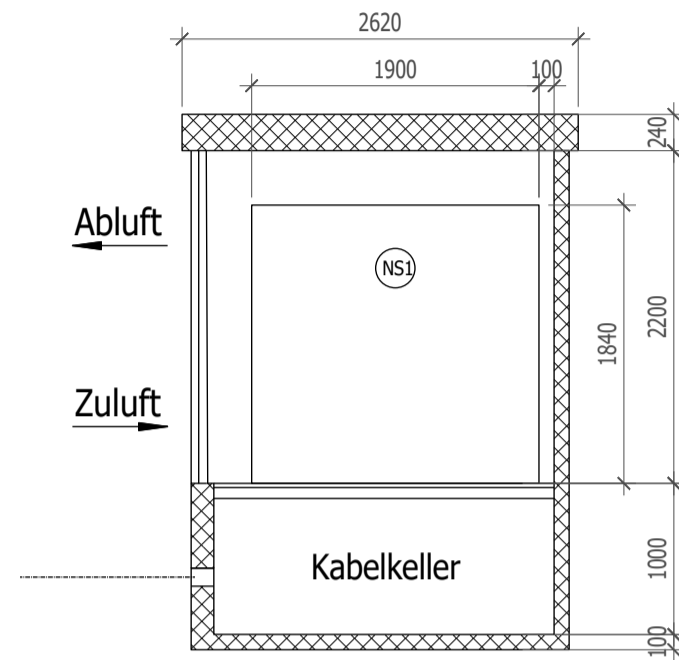

Schnitt B-B

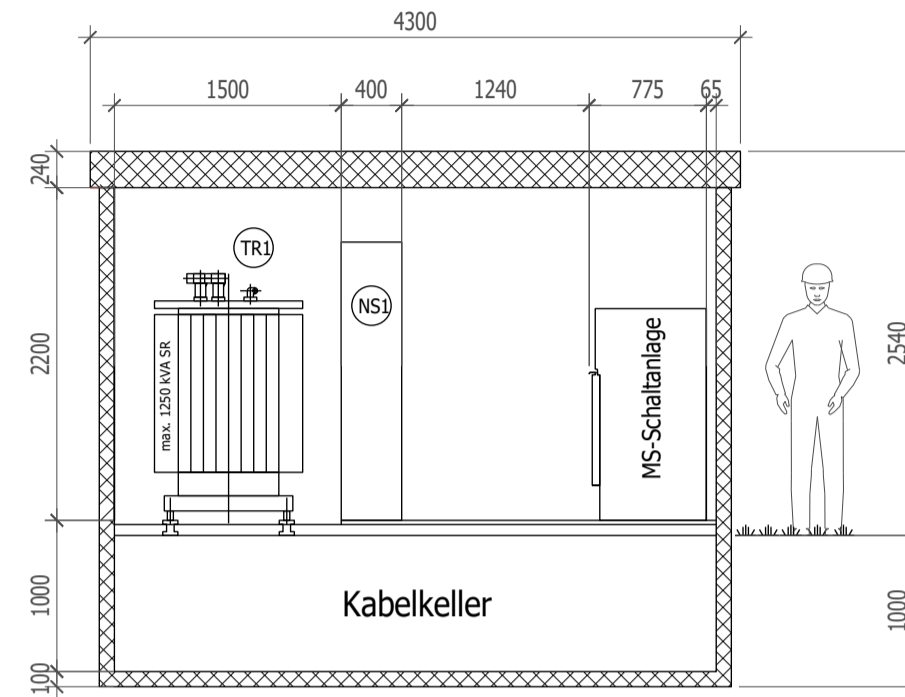

Schnitt C-C

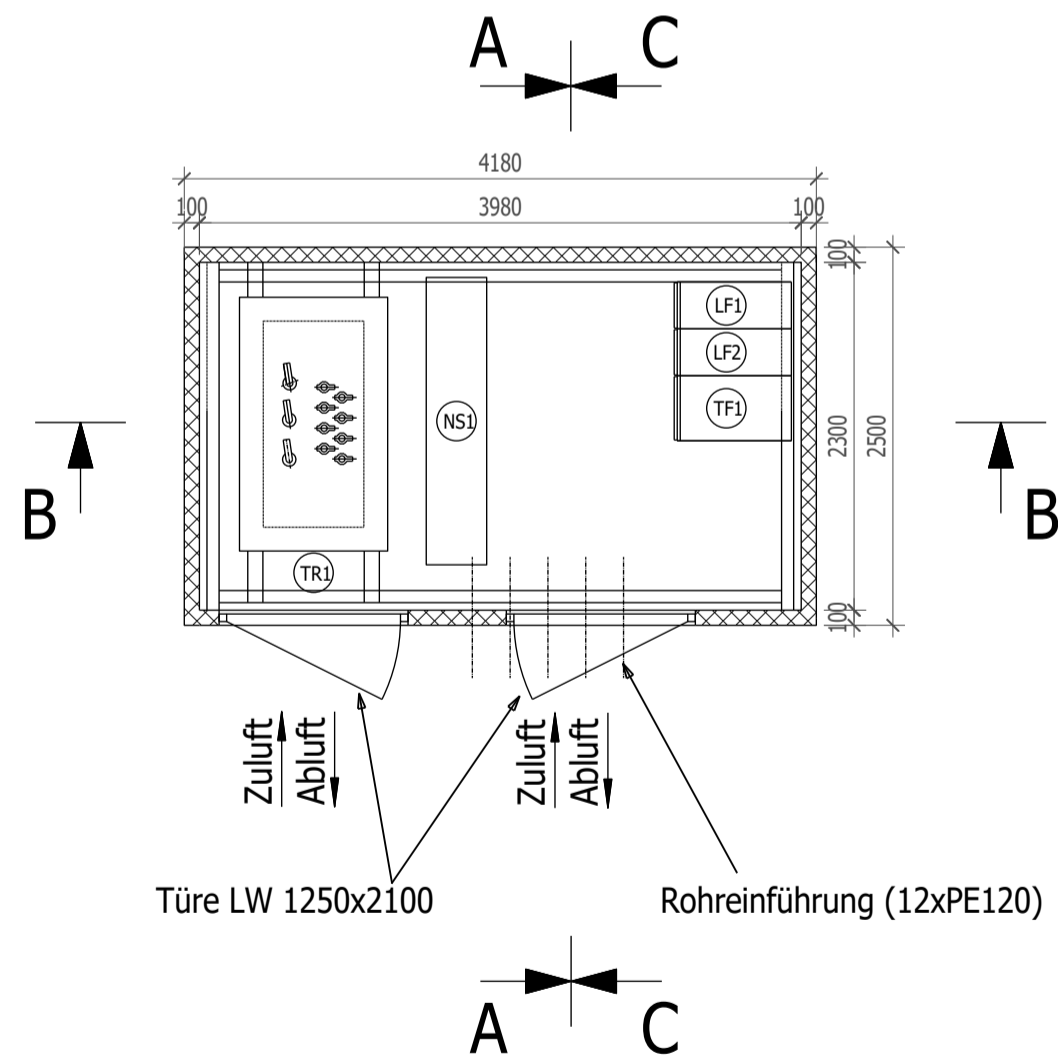
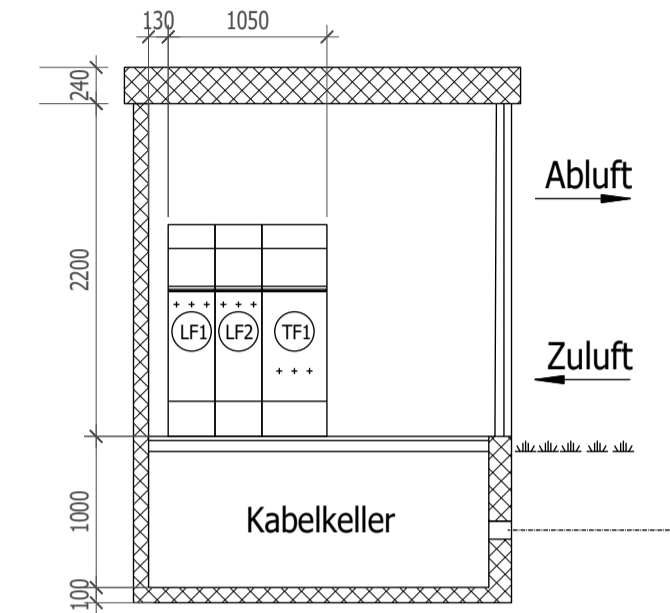

**Ausrüstung**

- (LF1) } MS-Anlage
- (LF2) } max. 5-feldrige-
- (TF1) } Kompaktschaltanlage
  
- (TR1) } Trafo max. 1250 kVA SR
- (NS1) } NSV-14 mit ÖB